

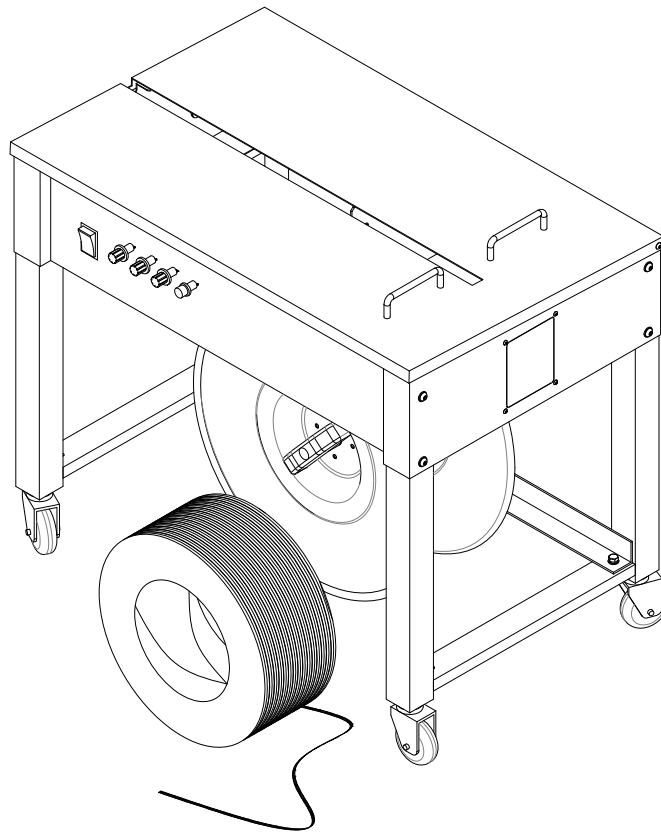

BERRAN INDUSTRIAL GROUP, INC.

570 Wolf Ledges Pkwy, Akron OH, 44311 (330) 253-5800 | Fax: (330) 253-5805

Eagle SP11 Semi Automatic Strapping Machine Use, Maintenance And Spare Parts Handbook



BERRAN INDUSTRIAL GROUP, INC.



Machine can only be operated by qualified personnel.

Daily safety guide

- Please refer to the following information if you need to operate or maintain this machine.

Before use

- Read this manual carefully and prepare yourself well before using.
- Check the cover board of the machine. If it is broken replace it with a new one (original part is recommended).
- Make sure that no tools or other items are on the machine. It is essential that this is kept tidy.
- Read the operation and maintenance instructions carefully.
- Read through the explanatory phase and take note of important identification relating to the machine application very carefully.

During use

- Do not wear any loose fitting clothes, in case they become trapped in the machine.
- Do not operate or maintain the machine without wearing suitable footwear.
- Keep your hands a suitable working distance away from other items.
- Do not use the machine to strap the products beyond the scope of application.

After use

- Make sure all of the switches are turned off.



Machine can only be operated by qualified personnel

Service and safety regulations

- Please keep the service contents.
- Do not change the setting or add any lubricant whilst the machine is in operation.
- Please turn off the power supply before opening the cover board.
- Do not install any additional parts for the sake of the normal application of the machine.
- Please use the original parts. Do not use any alternatives.
- Please use the power-supply system in line with the machine requirement.
- Do not tear off or cover the type specification or safety warning mark on the machine.
- Operate the machine according to the manual.



Machine can only be operated by qualified personnel.

Notice

- For the normal running of the machine, please keep both the machine and parts clean. Add lubricant to any of the parts that need lubricating.
- The machine can only be operated by relevant technical personnel.

INDEX

Part1 MACHINE PROPERTY AND SAFETY INFORMATION -----	5
1-1 Company name -----	5
1-2 Performance parameter -----	5
1-3 Machine nameplate -----	5
1-4 Outline and application field -----	6
1-5 Safety cautions to operate machine -----	6
1-6 Machine radiation safety -----	6
1-7 Safety sign -----	7
PART 2: MACHINE SPECIFICATION AND DEBUG -----	9
2-1 Specification -----	9
2-2 Transportation and storage conditions -----	9
2-3 Debug-----	10
PART 3. MACHINE OPERATION -----	11
3-1 Functions of control panel -----	11
3-2 Method of feeding strap -----	12
3-3 Operation steps -----	12
3-4 Daily maintenance -----	13
3-5 The position required to be adjusted -----	14
PART4. MAINTENANCE AND TROUBLESHOOTING -----	16
4-1 Safety warning on maintenance -----	16
4-2 Regularly maintenance and cleaning -----	16
4-3 Frequent trouble and troubleshooting -----	17
4-4 Random supply standard accessories -----	18
PART 5. MAIN PARTS AND COMPONENTS ILLUSTRATION AND PARTS LIST -----	19
5-1 Cassette mechanism unit -----	19
5-2 Strap plate unit -----	35
5-3 Machine frame-----	37
PART 6. ELECTRICAL WIRING DIAGRAM -----	39

PART 1: MACHINE PROPERTY AND SAFETY INFORMATION

1-1 Company name: Berran Industrial Group, Inc.
Manufacturer address: 570 Wolf Ledges Parkway
 Akron, Ohio 44311

1-2 Performance parameter

Item	Technical parameter
Power supply	AC110V, 50/60Hz, 0.25kW, DC motor
Working speed	3 second/path
Strapping force	0~50kg
Strap size	polypropylene
	Width (5mm~15mm) ±1mm, thickness (0.5mm~0.8mm)±0.1mm
	rell coil of strip width: 160mm~190mm
	Coil diameter: 200mm~210mm,external diameter:400mm~500mm
Outside dimension	L750mm×W550mm×H750mm
Worktable height	750mm
Machine weight	74kg
Working noise	≤75dB(A)
Environment	Humidity≤90%, temperature 0℃~40℃
Bottom adhesive	Hot melt: face ≥90%,width ≥20%, deviation of position≤2mm

1-3 Machine nameplate

If there are any questions and contact needs to be made with the manufacturer, please supply the model no and serial no of the machine. For detailed information of the machine refer to the machine nameplate. (FIG 1-1)



FIG1-1

1-4 Outline and application field

This machine adopts a new model single chip circuit: The single chip module board controls the whole action of strapping, design of super undertone. The assembly of the whole machine is precise and sophisticated, low noise will reduce the working pressure. The design of this new model, with electric heating and steel sheet, helps to ensure that there will be no short-circuit. When one duty cycle operation finishes, the machine will stop automatically to save power.

1-5 Safety cautions to operate machine

① Please confirm the power supply for the machine. Do not plug in the wrong power supply.

This machine adopts a 2-phase and flex is grounding zero line as electric leakage guard.

② Do not clean the machine with water, if the workplace is humid. The operating staff should not operate the machine if wearing unsuitable footwear.

③ Do not change or increase and decrease the parts unless you have to.

④ Do not apply oil to the roller wheel surface of the transport strap.

⑤ While the machine is not in use, please disconnect the power plug.

⑥ Main parts and components listed in the manual should frequently be lubricated by oil.

(Refer to page 3-4-1).

⑦ As used in the industries of explosion-proof, explosion-proof motors and other electrical appliances, these should be used in configuration.

⑧ Do not change, increase or remove any of the flame-proof parts freely. For surface maintenance you must contact either the original manufacturer or your supplier.

⑨ Products used shall conform to the product specification, explosion-proof components operating instructions and GB 3836.13 1997, 3836.16 GB - 2006 and GB 50257-1996 rules.

1-6 Machine radiation safety

Noise: $\leq 75\text{dB(A)}$

1-7 Safety sign

1-7-1 Safety sign labeling locations

On the device using a variety of warnings, instructions, and indication marks, these signs are to remind you to pay attention to the potential danger and provide instructions to avoid possible danger. (as shown in figure 1 and 2).

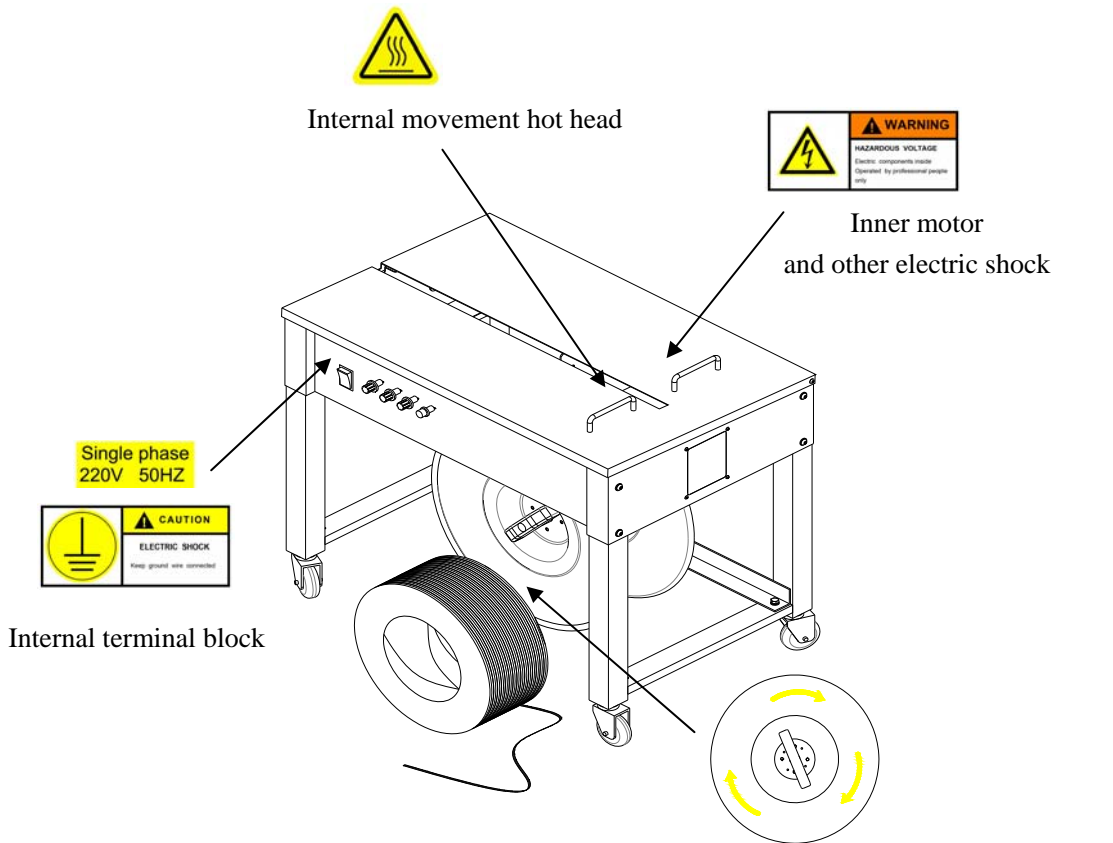



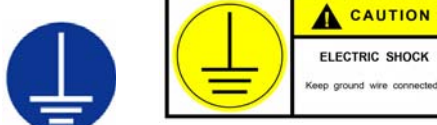

FIG 1-2

Direction signs uniform $\times 3$, for all reel

1-7-2 Safety signs Description

Safety signs Description table

NO.	Logo graphic	Symbol meaning	Remark (label location)
1		warning sign attention to safety	Easy to cause injuries
2		warning sign Danger High Voltage	Possible shock hazard electrical equipment and wiring
3		warning sign Beware of burns	Machine parts and other heat-generating part or heating at high temperature
4		Instruction sign Must be grounded	Lightning protection, anti-static place

PART 2: MACHINE SPECIFICATION AND DEBUG

2-1 Specification

- 2-1-1 model : Eagle SP11
- 2-1-2 N/W: 74kg
- 2-1-3 G/W: 82kg
- 2-1-4 Volume: 0.30m³
- 2-1-5 manufacturing date: refer to certificate of soundness
- 2-1-6 place of manufacture: Akron, Ohio

2-2 Transportation and storage conditions

2-2-1 Machine structure illustration (FIG 2-1)

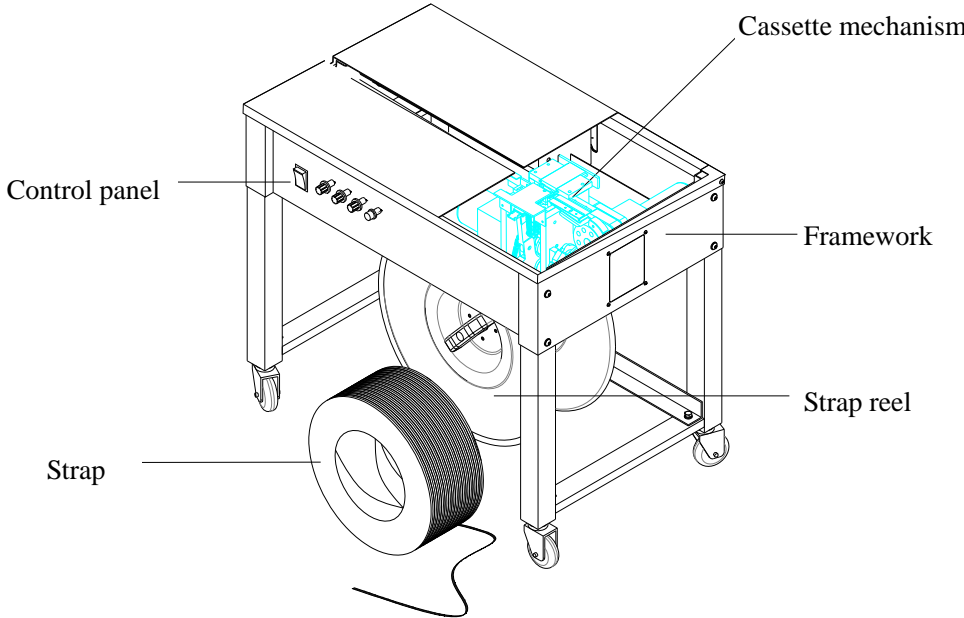

FIG 2-1

2-2-2 Transportation

Forklift truck forks to lift at the bottom of the machine removing the bottom bracket first. Forklifts should pay attention to safety. Also whilst mounted on the machine, there must be a large enough space. (refer to FIG 2-2)

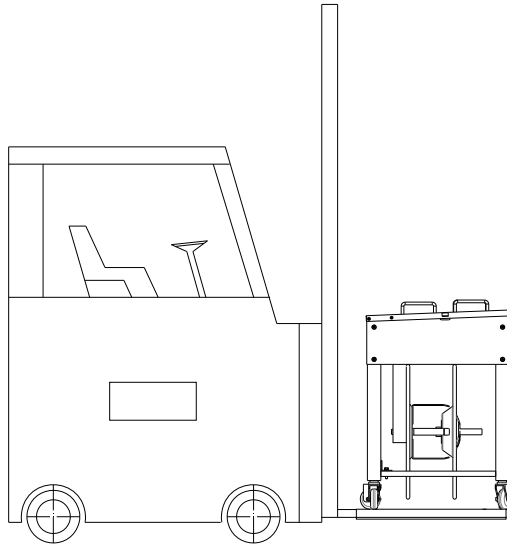

FIG 2-2

2-2-3 Operation environment conditions

For long-distance transport or long-term storage of the machine, you must use wooden or hardboard box packing, fixed on the solid backing plate and put in a box with moisture absorption agent, antirust coating inside the machine. Do not stack any heavy objects on top of the box. Do not transport and store the machine upside down.

Long-distance transport or long-term preservation of the machine, we recommend that the machine is connected to the power before manually checking all of the moving parts, in order to avoid overloading of electrical equipment.

2-3 Debug

Check before operation

- Check whether the fastened pieces have loosened.
- Check whether the motor and electrical equipment is dry, and that the insulation is good.
- Check whether the external power meets the requirement of machine power.

PART 3. MACHINE OPERATION

3-1 Functions of control panel (refer to FIG 3-1)

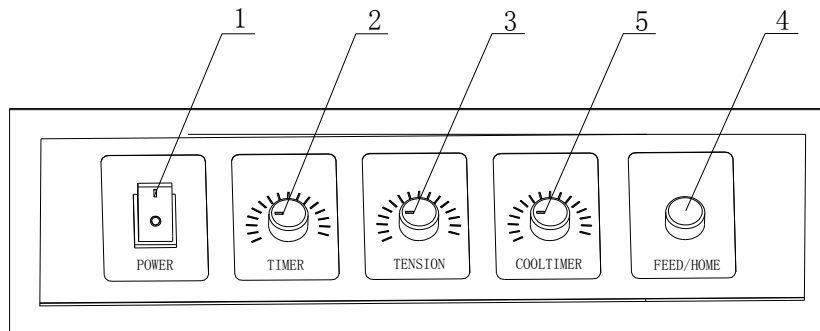

FIG 3-1

- ① **Power switch (POWER)**
- ② **Length adjustment of outputting strap (TIMER):** Every one scale is about 500mm. For any adjustment that is required turn it in the clockwise direction. The length of the strap will then become longer.
- ③ **Strap tension button (TENSION):** Choose the tension degree of strap according to the size of package.
- ④ **Manual feeding (FEED) / Reset button:** Push FEED button to help dispense the straps. The longer you push, the longer straps will be. If the machine is not at the start position, press the start button to ensure the machine reverts back to the start position.
- ⑤ **Cooling time adjustment: (COOL TIMER):** Depending on the strap and the different tensile strength, adjust the cooling time, so that the adhesive takes effect.

3-2 Method of feeding strap (6mm)

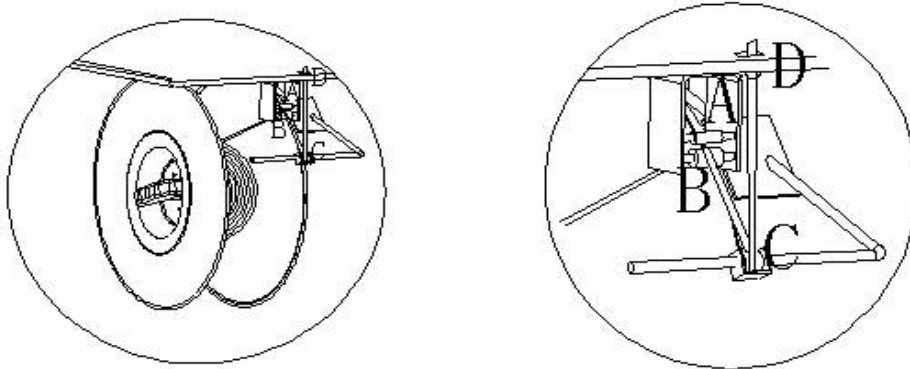

FIG 3-2

- Pull straps out from the strap reel and check whether the strap head is down (if not, then you need to change the side of strap reel), thread straps out from the bottom of pulley A and from the top of pulley B.
- Then thread the strap through wheel C and thread it upwards to the strap slot D which is on the bottom board firstly, then thread it upwards along the guide roll to the distance between rollers.
- Press FEED button, then the straps will dispense automatically.

3-3 Operation steps

- ① Thread straps according to the method in the FIG 3-2.
- ② Turn on the power switch 1 indicated in the FIG 3-1.
- ③ Put the package onto the machine close together to the barrier.
- ④ Pull the strap around the package and insert it along the strap-inserting path, then the machine will strap automatically.



warning:

Once the strap is fed into the slot the strap will immediately pull. At this point you must remove your hand immediately to ensure that no injuries occur.

3-4 Daily maintenance

Frequent maintenance of the strapping machine not only prolongs the life of the machine but also helps to avoid trouble, thus enabling it to increase production efficiency.

3-4-1 Charging lubricating oil

- ① Slide plate (refer to FIG 3-3), left cutter, middle cutter and right cutter (refer to FIG 3-4) should be lubricated with oil monthly.
- ② The place with the shaft and core bearing should be lubricated with oil once every 3 months.
- ③ Engine oil in the gearbox of the decelerator should be supplemented once every year.
- ④ Please notice that the following parts cannot be lubricated with oil:
 - a. Strap feeding and returning roller
 - b. Micro switch places

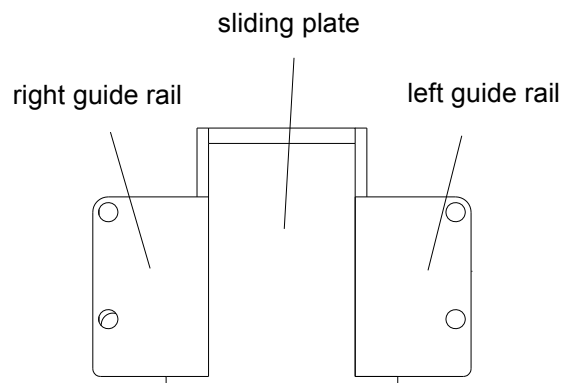

FIG 3-3

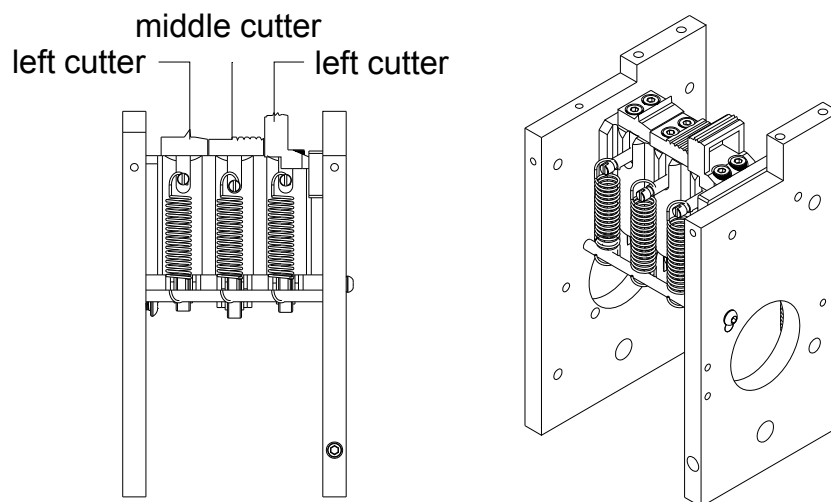

FIG 3-4

3-5 The position required to be adjusted

① Temperature adjustment: In the control cabinet of the machine and above the circuit board, open the cover plate of the control cabinet and you will see a potentiometer. Turn it in the clockwise direction and the temperature will increase. If the temperature is higher or lower than it should be, the adhesion level will not be as good as it should be. Therefore do not adjust too much as the difference in temperature will be too much. Adjust to between 4 and 5 and it will be fine (show as FIG3-5).

Note: The heating plate is a consumable. In order to extend the life of the heating plate if the temperature is too high, or if the machine is not in use, set the power switch to off.

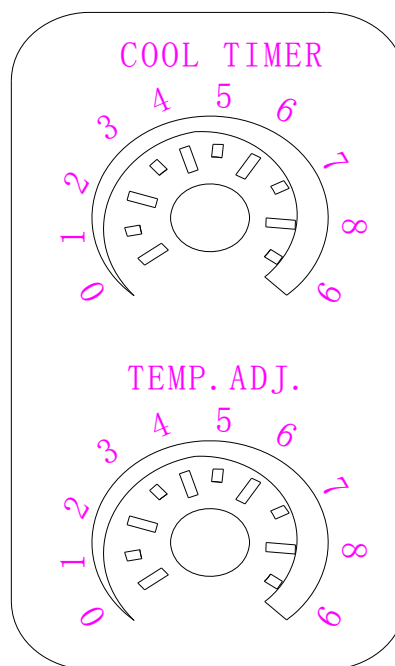

FIG 3-5

② Cooling time adjustment (COOL TIMER): In general, the temperature of the heater is sufficient, but because of different strap types, materials, and other factors, sometimes if you adjust the temperature it may not reach the perfect melting point. In such an instance, the adjuster can be adjusted (extended) two lead bonding (cooling) for a longer time, as the longer the cooling time, the adhesive strength is further strengthened. Clockwise cooling time is longer, and the adjustment is made in 0 seconds. (Refer to FIG 3-5).

③ To tighten the adjustment there is a potentiometer button marked “TENSION”. Turn it in the clockwise direction to tighten. If the strap does not tighten you need to adjust the pendulum block and increase the power.

Note: Do not adjust too much at once.

④ Width adjustment: This machine has a special design, 5mm-15mm. All can be used without changing any parts. If you need to adjust the strap insert hole, the spacing block of outputting straps (refer to FIG 3-6) and the spacing block's width of the outputting bottom plate (refer to FIG 3-7). The machine has been set for 12mm straps as standard at the factory.

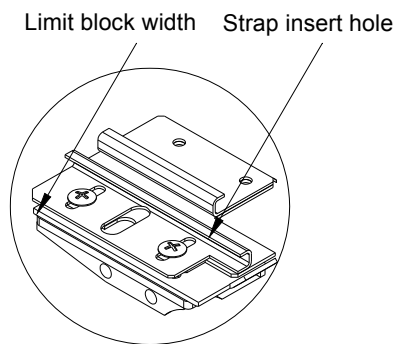

FIG 3-6

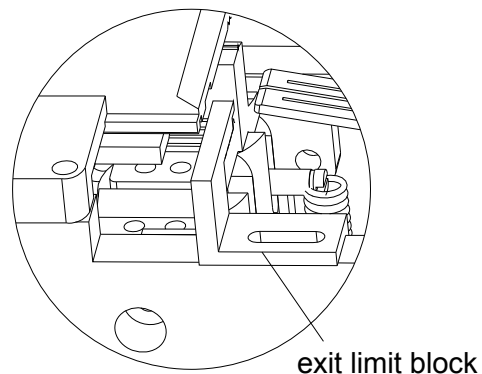

FIG 3-7

⑤ The length of outputting strap adjustment: There is a potentiometer button, marked “TIMER” on the switch panel; turn it in a clockwise direction, then the length of the strap becomes longer.

PART4. MAINTENANCE AND TROUBLESHOOTING

4-1 Safety warning on maintenance

- You must turn off the main power supply.
- The maintenance staff should wear suitable footwear whilst carrying out maintenance work.

4-2 Regularly maintenance and cleaning

Areas that require cleaning: sliding plate, left cutter, right cutter and middle cutter.

- Sliding plate: (Refer to FIG 3-3). Between the sliding plate, the left guide rail and right guide rail should fit exactly and the front movement of the sliding plate must be smooth. Therefore this position especially, needs to be cleaned and maintained. The cleaning procedure is summarized as follows:
 - A. Remove the tension spring below the sliding plate.
 - B. Move the sliding plate backward and take it out.
 - C. Clean the grooves of the sliding plate and left and right guide rail.
 - D. Install the sliding plate between the left and right guide rail and pull the spring.
 - E. Move the sliding plate forward and backward, check whether it moves smoothly. If it is necessary to adjust and the right guide rail cannot be adjusted, just adjusting the left guide rail will be ok.
 - F. Apply a little cart oil or light lubricant to the gap between the sliding plate and left and right guide rail.
 - G. If the sliding plate can move freely, but it cannot return back to its position, check whether the tensioning spring has worn out. If so, change it or cut it so that it is shorter.
- Regarding the left middle and right cutters, all of them must move up and down smoothly at the chamber base, or the machine cannot strap normally. Therefore cleaning and maintenance is very important. The method is as following: (refer to FIG 3-4).
 - A. Remove the tension spring on the middle and right cutters.
 - B. Move the upper sliding plate backward and take out the middle cutter first and then remove the right cutter.
 - C. Clean the middle and right cutter and the machine chamber base.
 - D. Install right cutter first, and install middle cutter and spring after.
 - E. Apply some light lubricant oil around all of the cutters.
 - F. If the machine is running for a long time, and the middle and right cutters cannot cut off the strap, then adjust the middle cutter closer to the right cutter a little. You must make sure that the middle cutter can move up and down smoothly; or change the cutter head of the middle cutter.

4-3 Frequent trouble and troubleshooting

- Cannot output straps automatically: in this situation, check whether the “adjustment of the length” of the strap is at “0” position first, and then check whether the strap threads correctly. For example, if the machine is at the zero position it will not release any straps. And if there is something that is large around the strap-feeding roller, this problem will happen too.
- Adhesive effect is not so good:
 - A. If the temperature is too high or too low, the viscosity of a special strap is not as good, The temperature must be correct.
 - B. Voltage is not enough: The power supply in many factories is often not enough. If you use an extension or cable wire, it will result in a reduction of power. So this lowers the original temperature and the strapping motor will burn out. Therefore the use of an extension or cable wire should be avoided. If the extension or cable wire must be used, adopt thicker, not longer wire.
 - C. If the 635 bearing below the middle cutter is damaged, then it only affects the warming and can't stick completely.
 - D. If the long spring of the pendulum bar is worn out, it cannot pull the pendulum bar to the correct position, thus leading to part adhesion.
 - E. If the electric heating steel sheet is not in the correct position so that it touches the PP straps on the top and bottom or left and right cutter, and so that it cannot heat up, adjust it according to the actual circumstance or application of use.
- Inserting strap, no action:
 - A. Trouble with inching switch on LS1 that is below the slide plate or shrapnel is stopped by something, and so it can't touch contact point.
 - B. The machine is not at the home position, so insert strap and if there is no action; it is necessary to push the reset button and start again at the beginning.
 - C. M1 motor 's carbon brush is wear; Motor does not turn or rotation powerless.
- Continue action:
 - A. LS1 trouble.
 - B. No trouble for LS1 other than a small object is caught between contact point and spring slice or the spring slice itself is caught so that it cannot be released after inserting the strap as usual.
 - C. situ micro switch (LS2) bad plug with no response. Press the jog host directly to stop after four laps in the cooling position (to the highest point of the cutter at the top); press the jog repeat this action. This behavior can be determined for the LS2 switch is broken.
 - D. Back with a micro switch (LS3) bad, insert after rebate with a belt. Host a turn directly back into place to stop, you can jog belt, insert strap and repeat this action. This behavior can be determined if the LS3 switch is broken.

4-4 Random supply standard accessories

- tension spring YS-2A-70 2 pieces
- socket head wrench 1set
- cross screwdriver 1 piece
- 8-10 wrench 2 pieces
- instruction book 1 piece
- certificate of soundness 1 piece

PART 5. MAIN PARTS AND COMPONENTS ILLUSTRATION AND PARTS LIST

5-1 Cassette mechanism unit

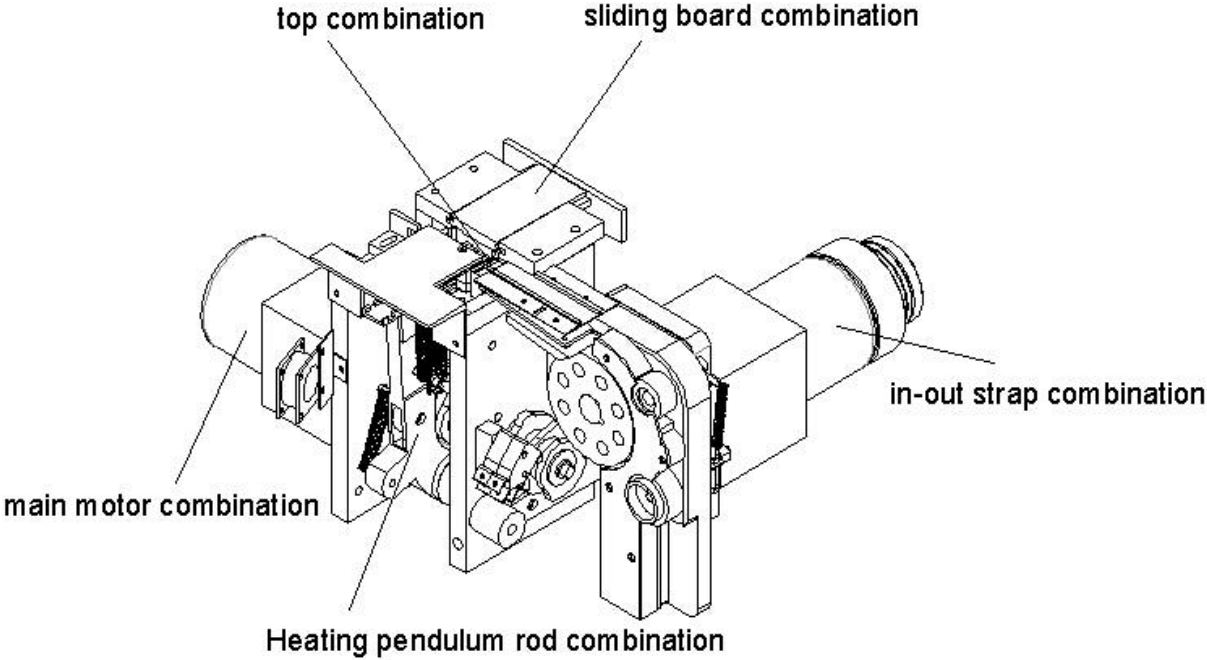

5-1-1 Main motor combination

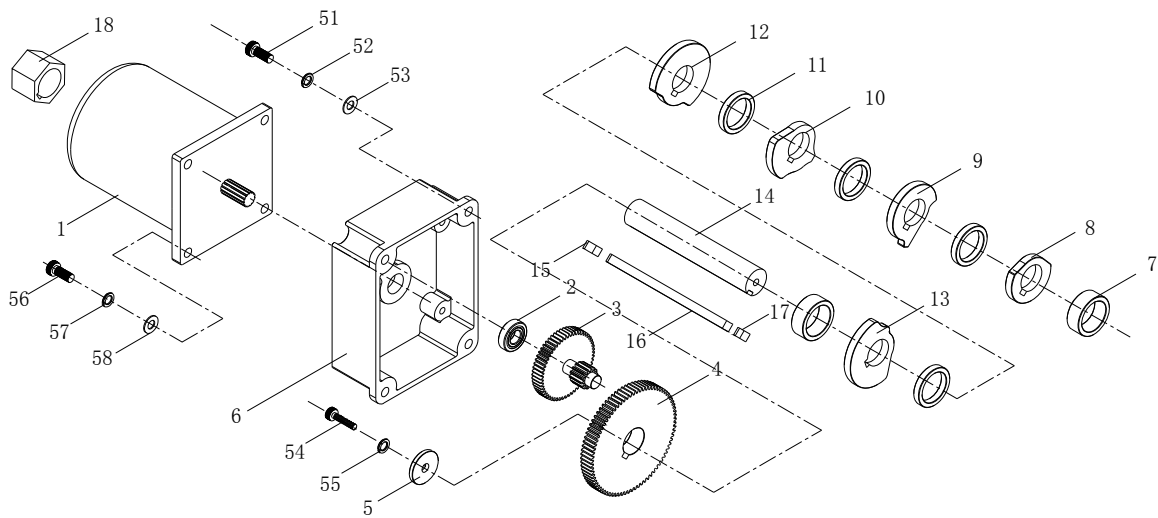

Detailed parts list

NO.	Name	Code	Qty	Remark
1	M1 motor	Z5D60-24GN-13S	1	
2	Bearing	6900	1	
3	Gear shaft	YS-2A-27	1	
4	Big gear	YS-2A-28	1	
5	Washer	YS-2A-65	1	
6	gear box cover	YS-2A-36	1	
7	Spacer bush	YS-2A-84	2	φ28×φ22.8×11
8	Cam	YS-2A-35	1	
9	Cam	YS-2A-33A	1	
10	Cam	YS-2A-31	1	
11	Spacer bush	YS-2A-84	4	φ28×φ22.8×5
12	Cam	YS-2A-32	1	
13	Cam	YS-2A-34A	1	
14	Main shaft	YS-2A-25B	1	
15	Flat key	6×6×10	1	
16	Flat key	6×6×70	1	
17	Flat key	6×6×28	1	
18	Motor set	YS-2A-114	1	
51	Inner hexagon screw bolt	M6×20	4	
52	Spring washer	φ6	4	
53	Flat washer	φ6	4	
54	Inner hexagon screw bolt	M6×20	1	
55	Spring washer	φ6	1	
56	Inner hexagon screw bolt	M6×20	4	
57	Spring washer	φ6	4	
58	Flat washer	φ6	4	

5-1-2 Cassette mechanism frame

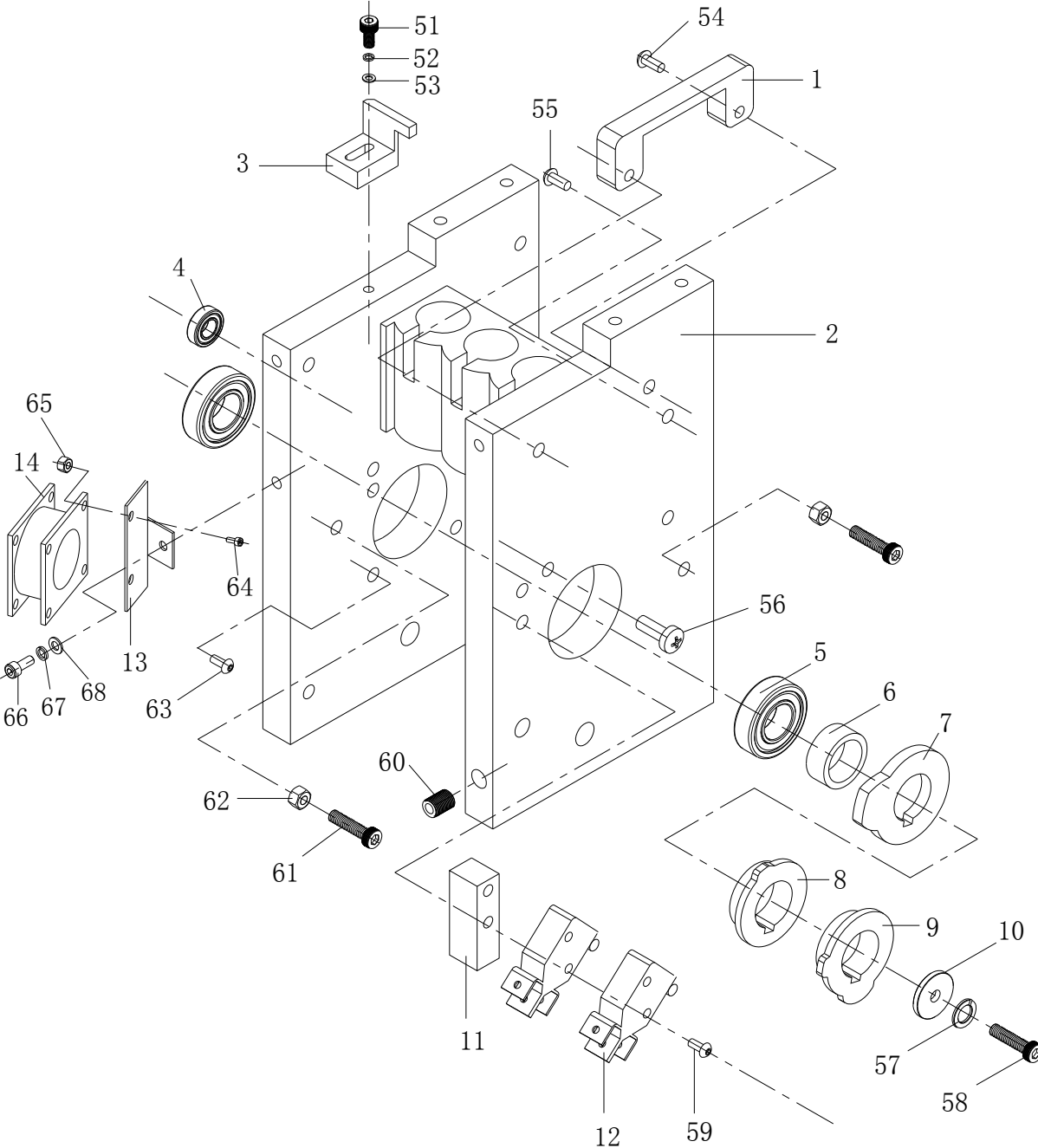

Detailed parts list

NO.	Name	Code	Qty	Remark
1	spacer parallel	YS-2A-51	1	
2	Cassette mechanism frame	YS-2A-01	1	
3	Limited plate	YS-2A-30	1	
4	Bearing	6900	1	
5	Bearing	6004	2	
6	spacer bush	YS-2A-84	1	φ28×φ22.8×5
7	Tied tight cam	YS-2A-117	1	
8	Situ cam	YS-2A-115	1	
9	Back with the cam	YS-2A-116	1	
10	Cushion block	YS-2A-65	1	
11	switch block	YS-2A-121	1	
12	Micro switch	KW-7(with rollers)	2	
13	Fan frame	YS-2A-107A	1	
14	Fan	XD8025	1	DC24V
51	Inner hexagon screw bolt	M4×12	1	
52	Spring washer	φ4	1	
53	Flat washer	φ4	1	
54	Cup head inner hexagon screw bolt	M5×12	2	
55	Cup head inner hexagon screw bolt	M6×20	2	
56	cross big flat head screw bolt	M4×8	1	
57	Spring washer	φ6	1	
58	Inner hexagon screw bolt	M6×20	1	
59	Inner hexagon screw bolt	M3×45	2	
60	set screw	M6×10	1	
61	Inner hexagon screw bolt	M4×16	2	
62	hexagon nut	M4	2	
63	Cup head inner hexagon screw bolt	M6×10 (12.9class)	4	
64	Inner hexagon screw bolt	M4×30	2	
65	hexagon nut	M4	2	
66	Inner hexagon screw bolt	M4×12	1	
67	Spring washer	φ4	1	
68	Flat washer	φ4	1	

5-1-3 Top body combination

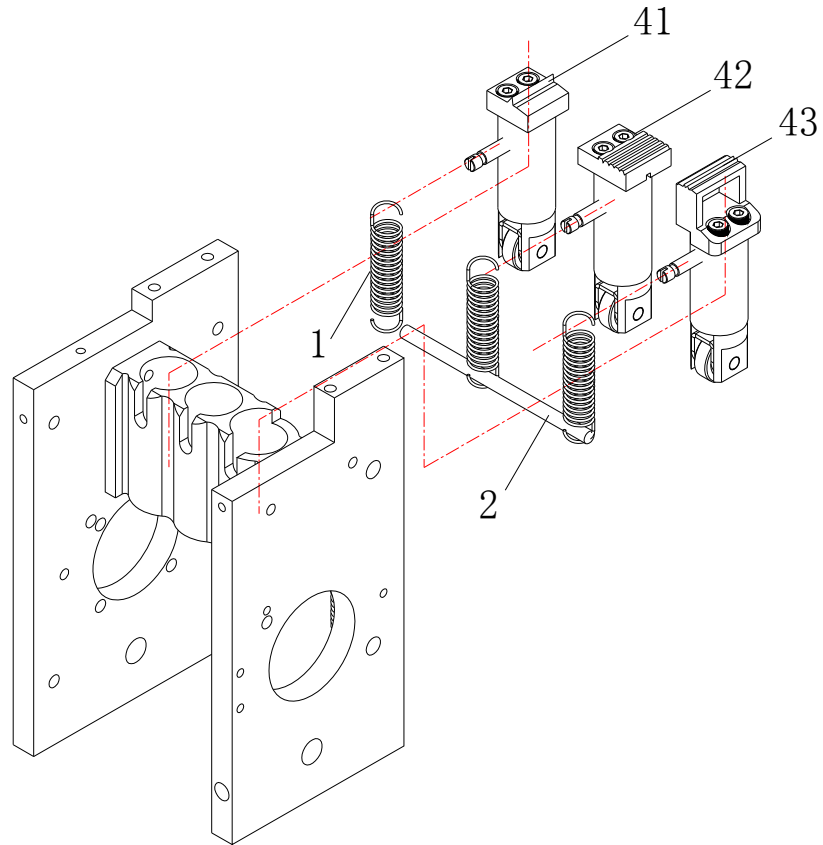

Detailed parts list

NO.	Name	Code	Qty	Remark
1	Extension spring	YS-2A-69	3	
2	Pull rod	YS-2A-43	1	
41	Left cutter combination	YS-2A-150	1	See diagram
42	Middle cutter combination	YS-2A-151	1	See diagram
43	Right cutter combination	YS-2A-152	1	See diagram

5-1-3-1 Left cutter combination

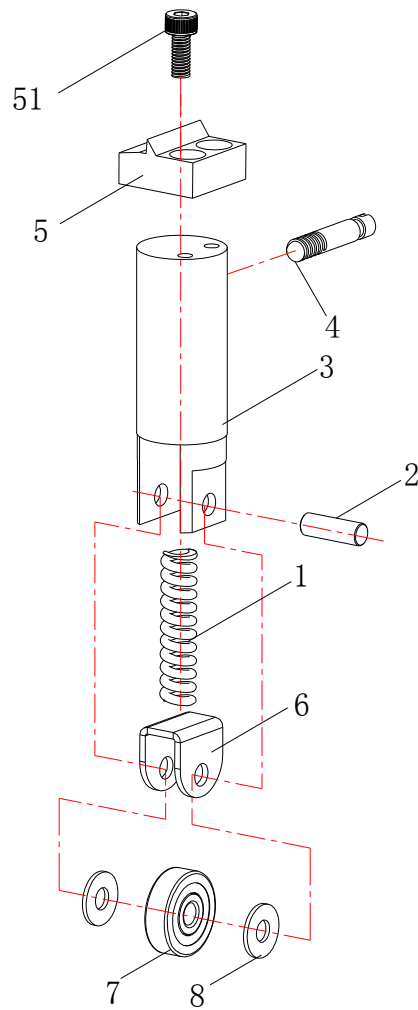

Detailed parts list

NO.	Name	Code	Qty	Remark
1	Compression spring	01-104	1	
2	Small shaft	YS-2A-44	1	
3	Left Cavity	YS-2A-18	1	
4	Small Bolt	YS-2A-53	1	
5	Left claw	YS-2A-19	1	
6	Pressing plate	YS-2A-50	1	
7	Bearing	635 (thicken)	1	
8	Washer piece	YS-2A-68	2	
51	Inner hexagon screw bolt	M4×12 (12.9class)	2	

5-1-3-2 Middle cutter combination

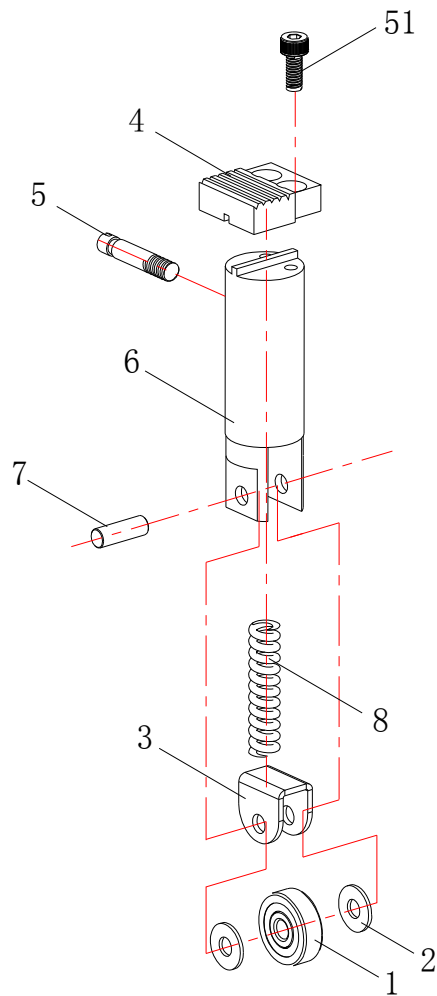

Detailed parts list

NO.	Name	Code	Qty	Remark
1	Bearing	635 (thicken)	1	
2	Washer	YS-2A-68	2	
3	Pressure Plate	YS-2A-50	1	
4	Middle cutter	YS-2A-17	1	
5	Small Bolt	YS-2A-53	1	
6	Middle Cavity	YS-2A-16	1	
7	Small shaft	YS-2A-44	1	
8	Compression spring	YS-2A-110	1	
51	Inner hexagon screw bolt	M4×12 (12.9class)	2	

5-1-3-3 Right cutter combination

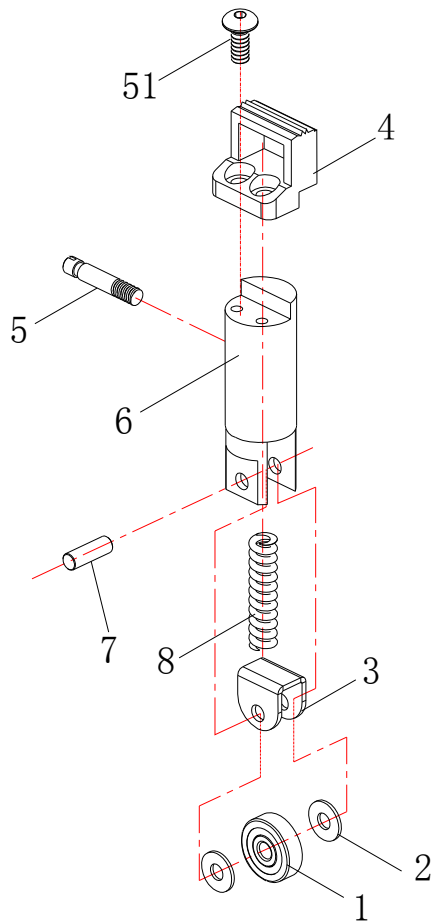

Detailed parts list

NO.	Name	Code	Qty	Remark
1	Bearing	635 (thicken)	1	
2	Washer piece	YS-2A-68	2	
3	Pressure Plate	YS-2A-50	1	
4	Right claw	YS-2A-15	1	
5	Small bolt	YS-2A-53	1	
6	Right chamber	YS-2A-14	1	
7	Small shaft	YS-2A-44	1	
8	Pressure spring	01-104	1	
51	Cup head inner hexagon screw bolt	M4×12 (12.9 class)	2	

5-1-4 Sliding board pendulum rod combination

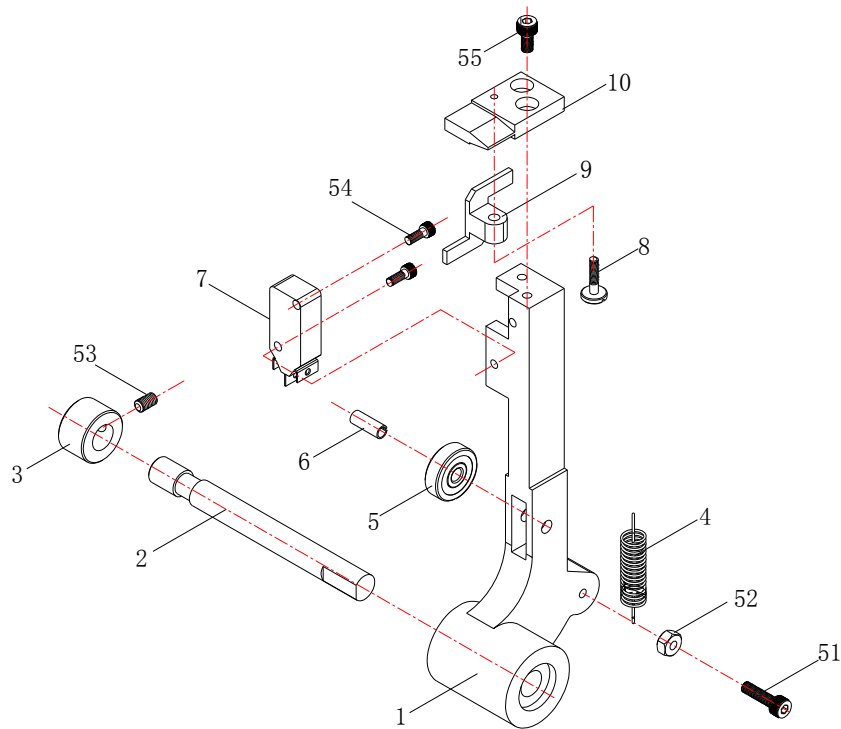

Detailed parts list

NO.	Name	Code	Qty	Remark
1	Pendulum rod	YS-2A-08	1	
2	Pendulum rod shaft	YS-2A-21	1	
3	Bead flange	YS-2A-52	1	
4	Extension spring	YS-2A-69	1	
5	Bearing	635 (thicken)	1	
6	Elastic spring	φ5×14	1	
7	Micro switch	RV-16-1C25(T)	1	
8	Special bolt	YS-2A-66	1	
9	Switch bump block	YS-2A-29	1	
10	Pendulum rod tongue	YS-2A-20	1	
51	Inner hexagon screw	M4×16	1	
52	hexagon nut	M4	1	
53	Fasten hexagon screw	M6×10	1	
54	Cross big brazier head screw	M3×16	2	
55	Inner hexagon screw	M4×8(12.9 class)	2	

5-1-5 Sliding board combination

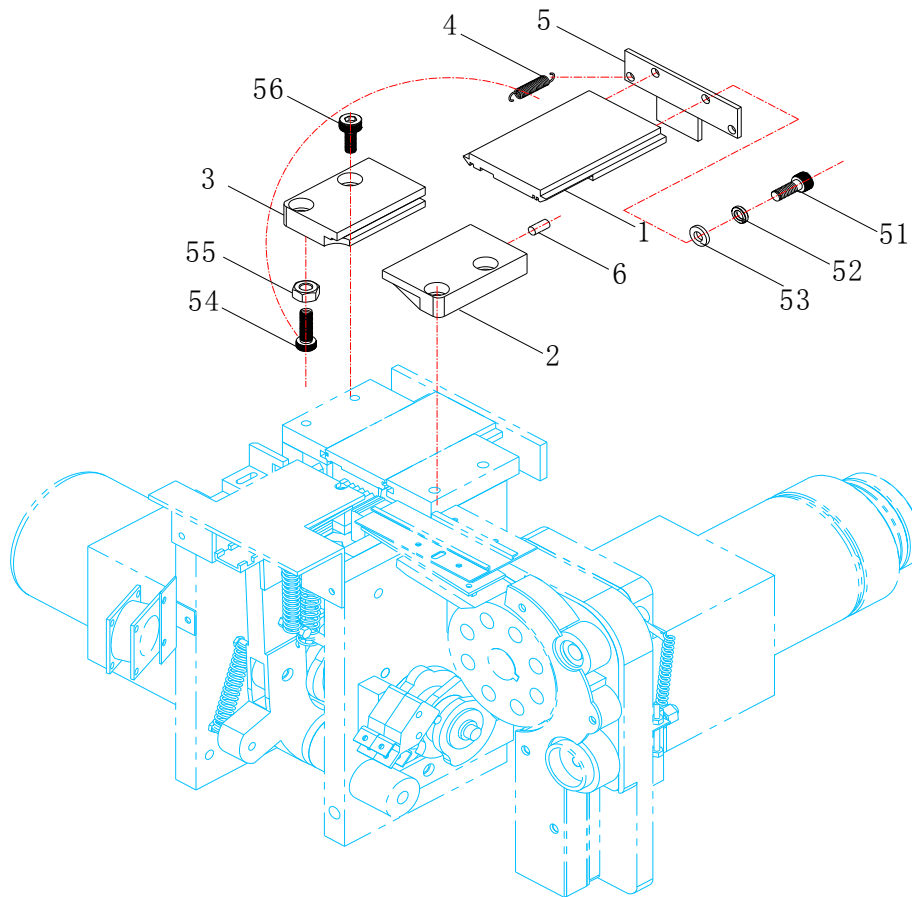

Detailed parts list

NO.	Name	Code	Qty	Remark
1	Sliding board	YS-2A-09	1	
2	Right guide rail	YS-2A-11	1	
3	Left guide rail	YS-2A-12	1	
4	Extension spring	YS-2A-70	2	
5	Sliding board bump block	YS-2A-10	1	
6	Damping washer	YS-2A-12A	2	
51	Inner hexagon screw	M3×10 (12.9 class)	2	
52	Spring washer	Φ3	2	
53	Flat spring	Φ3	2	
54	Inner hexagon screw	M4×16	2	
55	Hexagon screw	M4	2	
56	Inner hexagon screw	M5×16 (12.9 class)	4	

5-1-6 Heating pendulum rod combination

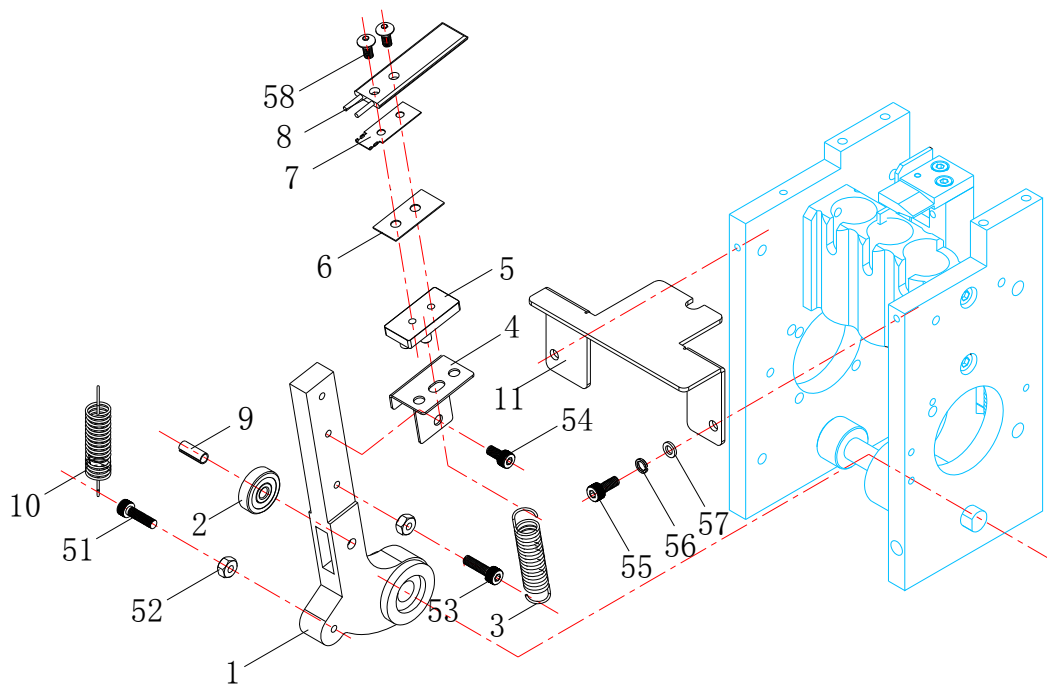

Detailed parts list

NO.	Name	Code	Qty	Remark
1	Heating pendulum rod	YS-2A-07	1	
2	Bearing	635(thicken)	1	
3	Extension spring	YS-2A-71	1	
4	Heating slice bracket	YS-2A-61A	1	
5	Heating head bottom board	YS-2A-62A	1	
6	Insulation film	YS-2A-108A	1	
7	Electric heating installation board	J50-57	1	
8	Electric heating head	J50-55	1	
9	Elastic pin	φ5×14	1	
10	Extension spring	YS-2A-69	1	
11	Guard board	YS-2A-103	1	
51	Inner hexagon screw	M4×16	1	
52	hexagon nut	M4	2	
53	Inner hexagon screw	M4×20	1	
54	Inner hexagon screw	M4×8	2	
55	Inner hexagon screw	M4×12	2	
56	Spring washer	Φ4	2	
57	Flat spring	Φ4	2	
58	Cross big brazier head screw	M4×10	2	

5-1-7 In-out motor combination

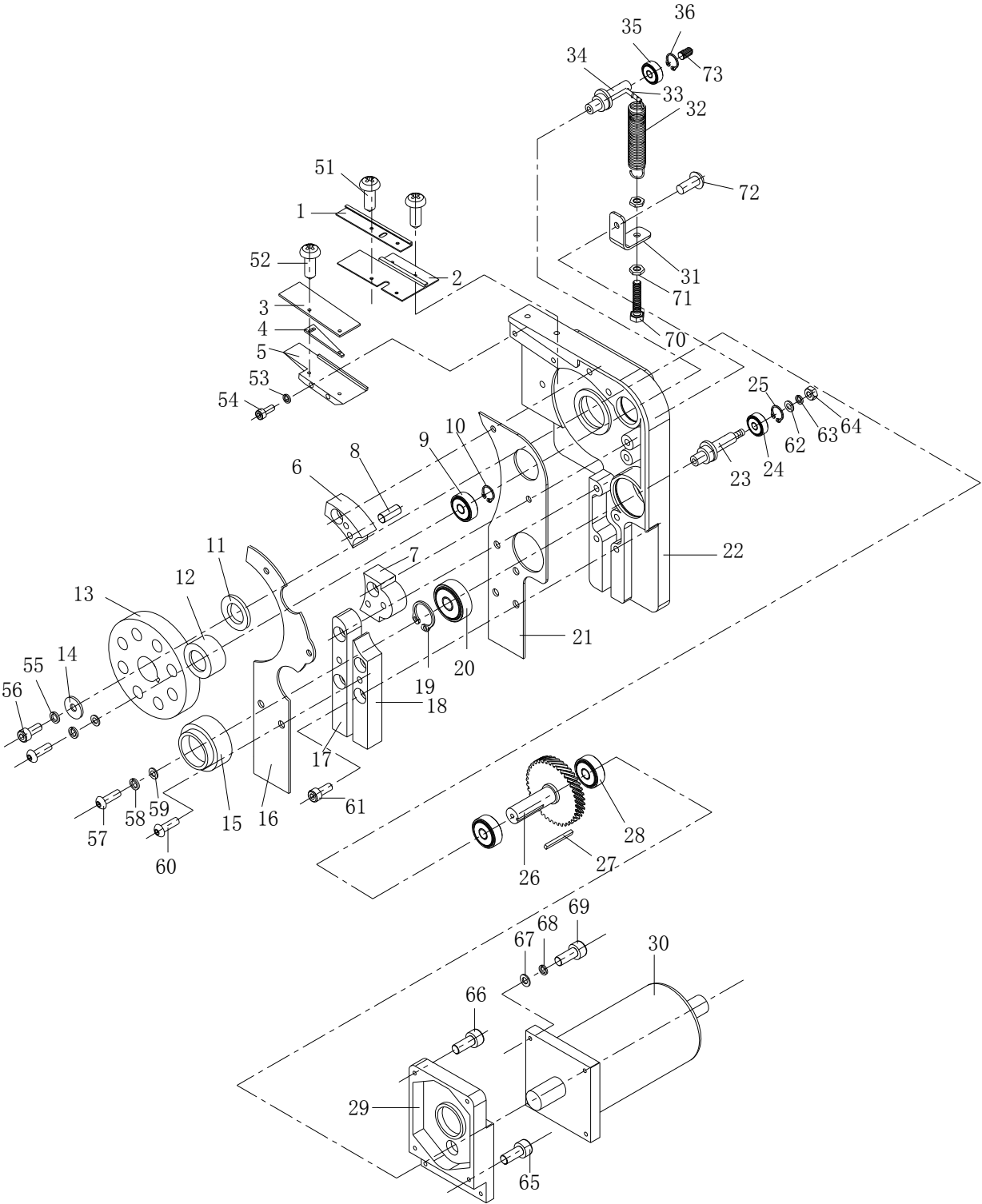

Detailed parts list

NO.	Name	Code	Qty	Remark
1	Insert strap groove limit board	YS-2A-41	1	
2	Insert strap groove bottom board	YS-2A-40	1	
3	Conveyor belt pressing plate	YS-2A-23A	1	
4	Limit plate	YS-2A-24A	1	
5	Conveyor belt base plate	YS-2A-22A	1	
6	Guide strap board	YS-2A-64	1	
7	Guide strap board	YS-2A-57	1	
8	round pin	φ5X10	2	
9	bearing	608	1	
10	jump ring	R-22	1	
11	Spacer bush	YS-2A-59	1	
12	Roller wheel	YS-2A-06A	1	
13	driving roller wheel	YS-2A-05B	1	
14	Spring washer	YS-2A-65	1	
15	driven pulley	YS-2A-04A	1	
16	cover plate	YS-2A-48A	1	
17	Guide strap board	YS-2A-46A	1	
18	Guide strap board	YS-2A-47A	1	
19	jump ring	R-22	1	
20	bearing	6900	2	
21	Seal plate	YS-2A-49B	1	
22	Roller wheel wallboard	YS-2A-03A	1	
23	eccentric shaft	YS-2A-39A	1	
24	Bearing	16002	2	
25	jump ring	S-15	1	
26	Inclined gear shaft	YS-2A-26	1	
27	flat key	5×5×30	1	
28	Bearing	16002	2	
29	Motor fix plate	YS-2A-37	1	
30	M2 motor	Z5D90-24GN-30S-4	1	
31	Tension spring hanging plate	YS-2A-58A	1	
32	tension spring	YS-2A-111	1	
33	Small column	YS-2A-55A	1	
34	eccentric shaft	YS-2A-38A	1	
35	bearing	6900	2	
36	jump ring	S-10	1	
51	cross big brazier head screw	M4×8	4	
52	cross big brazier head screw	M4×10	2	
53	Spring washer	φ4	2	
54	Inner hexagon screw	M4×40	2	

55	Spring washer	φ6	1
56	Inner hexagon screw	M6×16	1
57	Cup head inner hexagon screw	M5×12	2
58	Spring washer	φ5	2
59	Flat washer	φ5×12	2
60	cross big brazier head screw	M4×8	4
61	Inner hexagon screw	M5×16	6
62	Flat washer	φ6	1
63	Spring washer	φ6	1
64	hexagon nut	M6	1
65	Inner hexagon screw	M6×20	2
66	Inner hexagon screw	M6×16	2
67	Flat washer	φ6	4
68	Spring washer	φ6	4
69	Inner hexagon screw	M6×20	4
70	Outer hexagon screw	M5×35	1
71	hexagon nut	M5	2
72	Cup head inner hexagon screw	M5×12	1
73	set screw	M5×6	1

5-1-8 Bundle tight combination adjustment

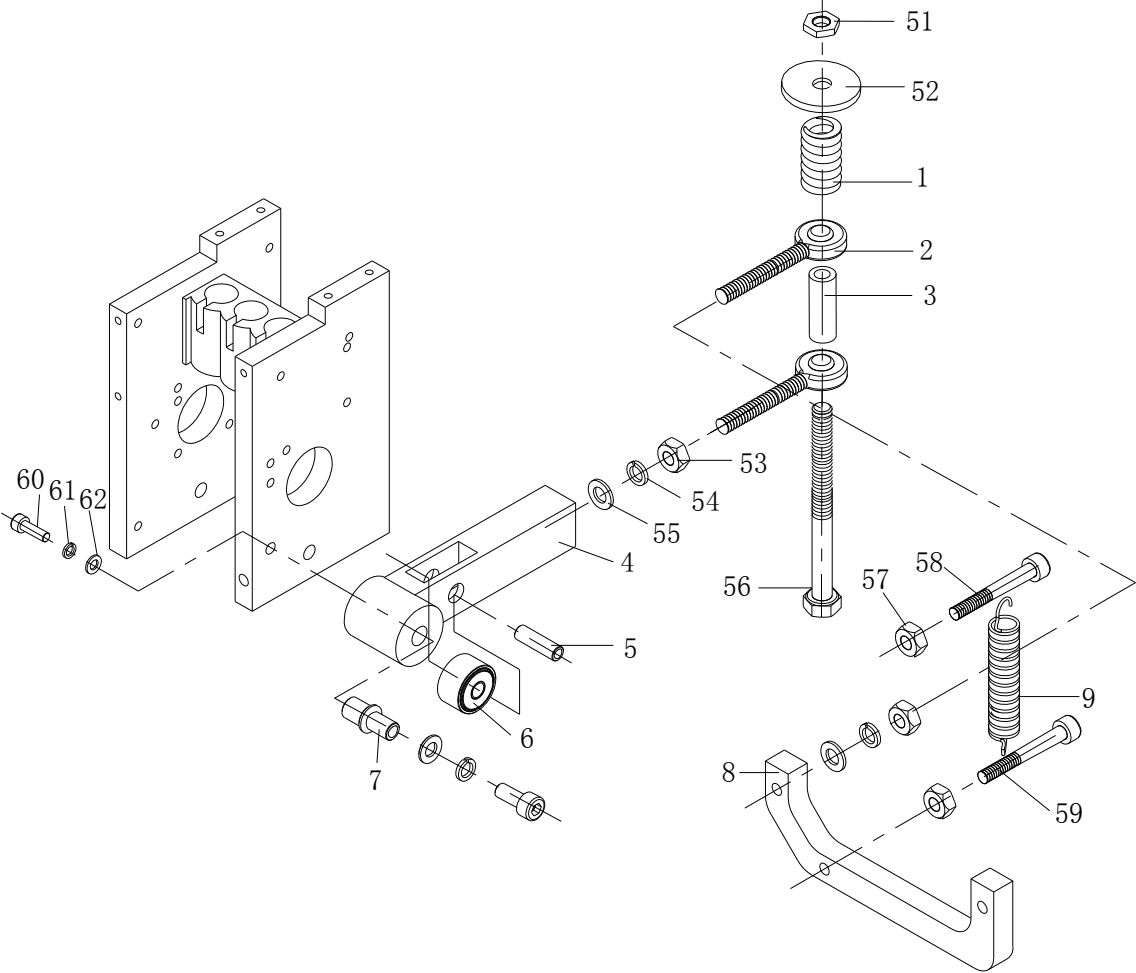

Detailed parts list

NO.	Name	Code	Qty	Remark
1	pressure spring	YS-04-161A	1	
2	rod end knuckle bearing	φ6	2	
3	Washer cover	YS-2A-118	1	
4	Bundle tight rod	YS-2A-119	1	
5	spring pin	φ5×12	1	
6	Bearing	635 (thicken)	1	
7	Bundle tight rod bearing	YS-2A-120	1	
8	oscillating deck	YS-2A-56B	1	
9	pressure spring	YS-04-212	1	
51	stop back nut	M6	1	
52	Flat washer	φ6	2	
53	hexagon nut	M6	2	
54	Spring washer	φ6	2	
55	Flat washer	φ6	2	
56	Out hexagon screw	M6×75	1	
57	hexagon nut	M5	2	
58	inner hexagon screw	M5×35	1	
59	inner hexagon screw	M5×16	1	
60	Cup head inner hexagon screw	M5×12	2	
61	Spring washer	φ5	2	
62	Flat washer	φ5×16	2	

5-2 Strap plate unit

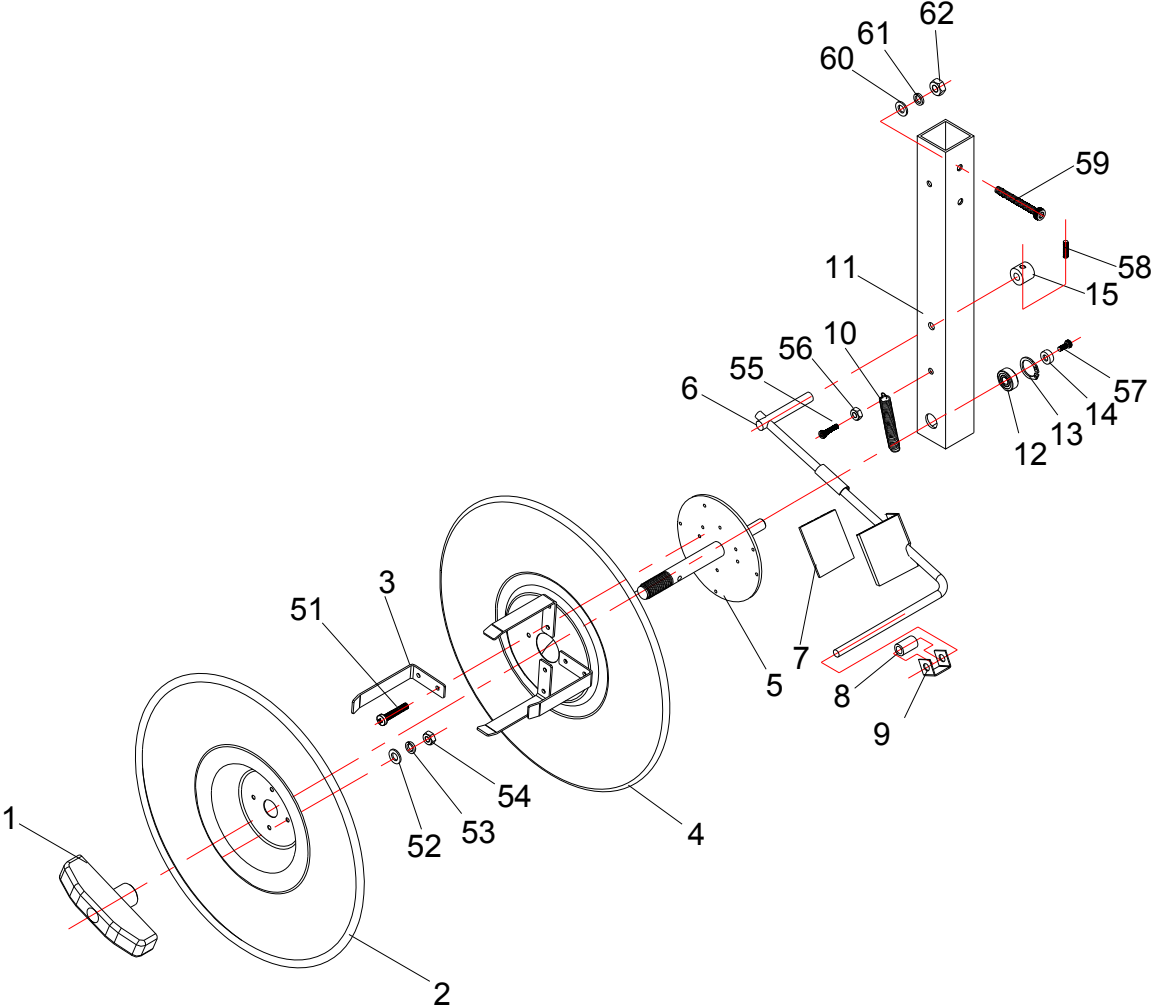

Detailed parts list

NO.	Name	Code	Qty	Remark
1	Hand wheel	00-192	1	
2	External strap plate	A0061	1	
3	Support claw	00-143	4	
4	Inner strap plate	A0060	1	
5	tape spool bearing	A0050	1	
6	Brake rod	YS-2A-86	1	
7	Brake rubber slice	YS-2A-101	1	
8	Small guide strap wheel	YS-2A-75	1	
9	Guide wheel frame	J50-69	1	
10	Extension spring	YS-2A-73	1	
11	Square pipe	YS-2A-85	1	
12	Bearing	6203 (with card slot)	2	
13	Circlip	R-40	2	
14	Washer ring	YS-2A-65	1	
15	Small fixed sleeve	YS-2A-67	1	
51	Out hexagon screw	M6×16	8	
52	Flat washer	φ6	8	
53	Spring washer	φ6	8	
54	Nut	M6	8	
55	Inner hexagon screw	M4×20	1	
56	Nut	M4	1	
57	Inner hexagon screw	M6×20	1	
58	Fasten screw	M6×10	1	
59	Inner hexagon screw	M8×65	3	
60	Washer piece	φ8	3	
61	Spring washer	φ8	3	
62	Nut	M8	3	

5-3 Machine frame

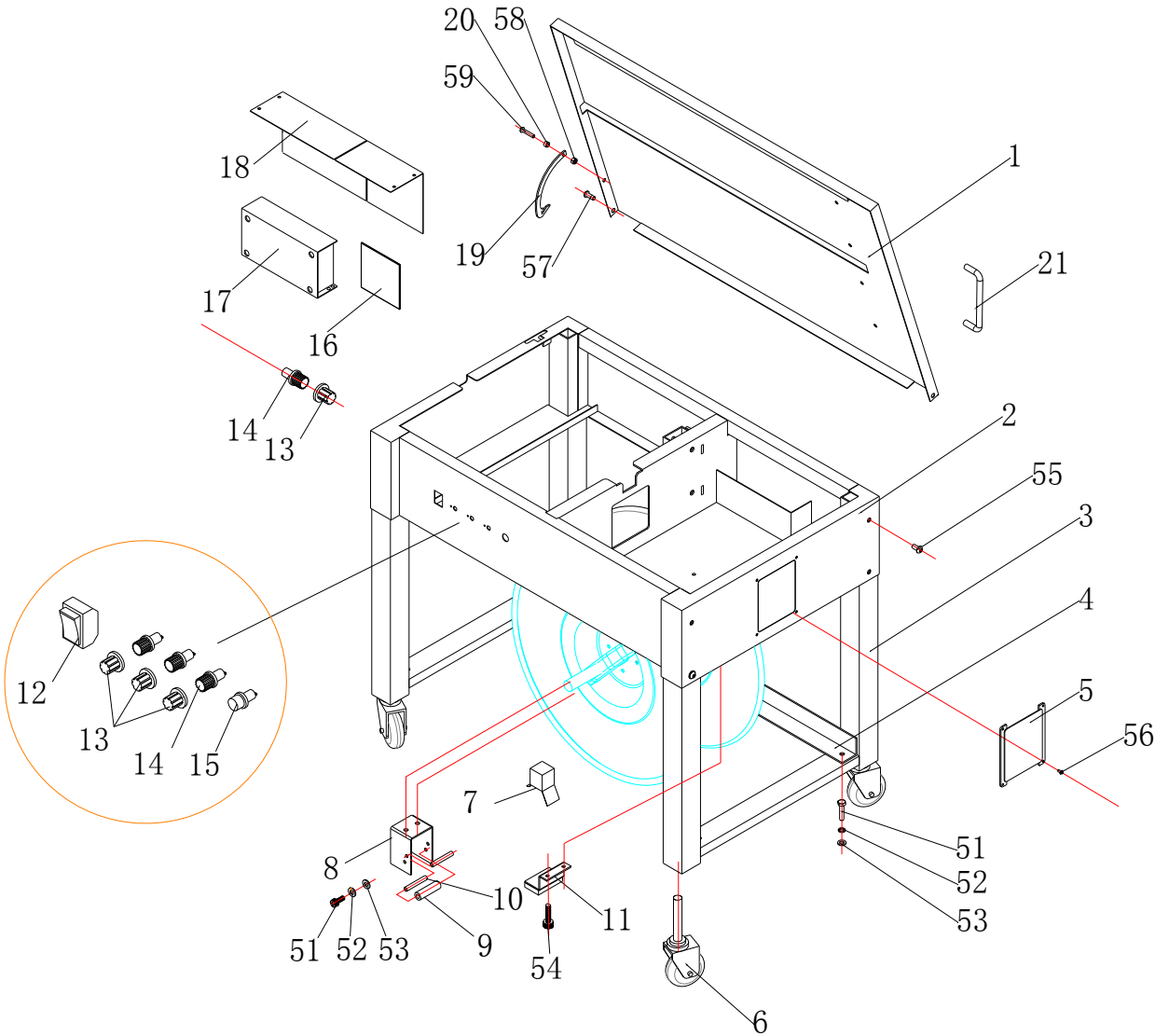

Detailed parts list

NO.	Name	Code	Qty	Remark
1	Panel	YS-2A-305	1	
2	Framework	YS-2A-300	1	
3	Leg tube	YS-2A-302	2	
4	Supporting of leg tube	YS-2A -303	1	
5	Shrouding	YS-2A-301	1	
6	Foot wheel	Screw universal 3 "Black	4	2with brake, 2 without brake
7	Insert groove	YS-2A-105	1	
8	Big guide strap frame	YS-2A-83	1	
9	Big guide strap wheel	YS-2A-74	1	
10	Big guide strap shaft	YS-2A-76	2	
11	Brake rod blocking plate	YS-2A-97	1	
12	Switch button	R13-87	1	
13	Potential device knob	Black 17×13	4	
14	Potential device	BK250	4	
15	inching button	LA160-16A	1	
16	PC plate	YS-F502	1	
17	Switch button	S-250-24	1	
18	Electrical box lid	YS-2A -304	1	
19	Arc support	AS1-611	1	
20	Supporting collar	AS1-612	1	
21	Handle	00-210	2	
51	Inner hexagon screw	M6×12	10	
52	Spring washer	Φ6	10	
53	Flat washer	Φ6	10	
54	Inner hexagon screw	M4×8	2	
55	Cup head inner hexagon screw	M8×16	8	
56	Cross big flat head screw bolt	M4×8	4	
57	Special Cup head inner hexagon screw	M6×12	2	
58	Stop back nut	M6	1	
59	Cup head inner hexagon screw	M6×16	1	

PART 6. ELECTRICAL WIRING DIAGRAM

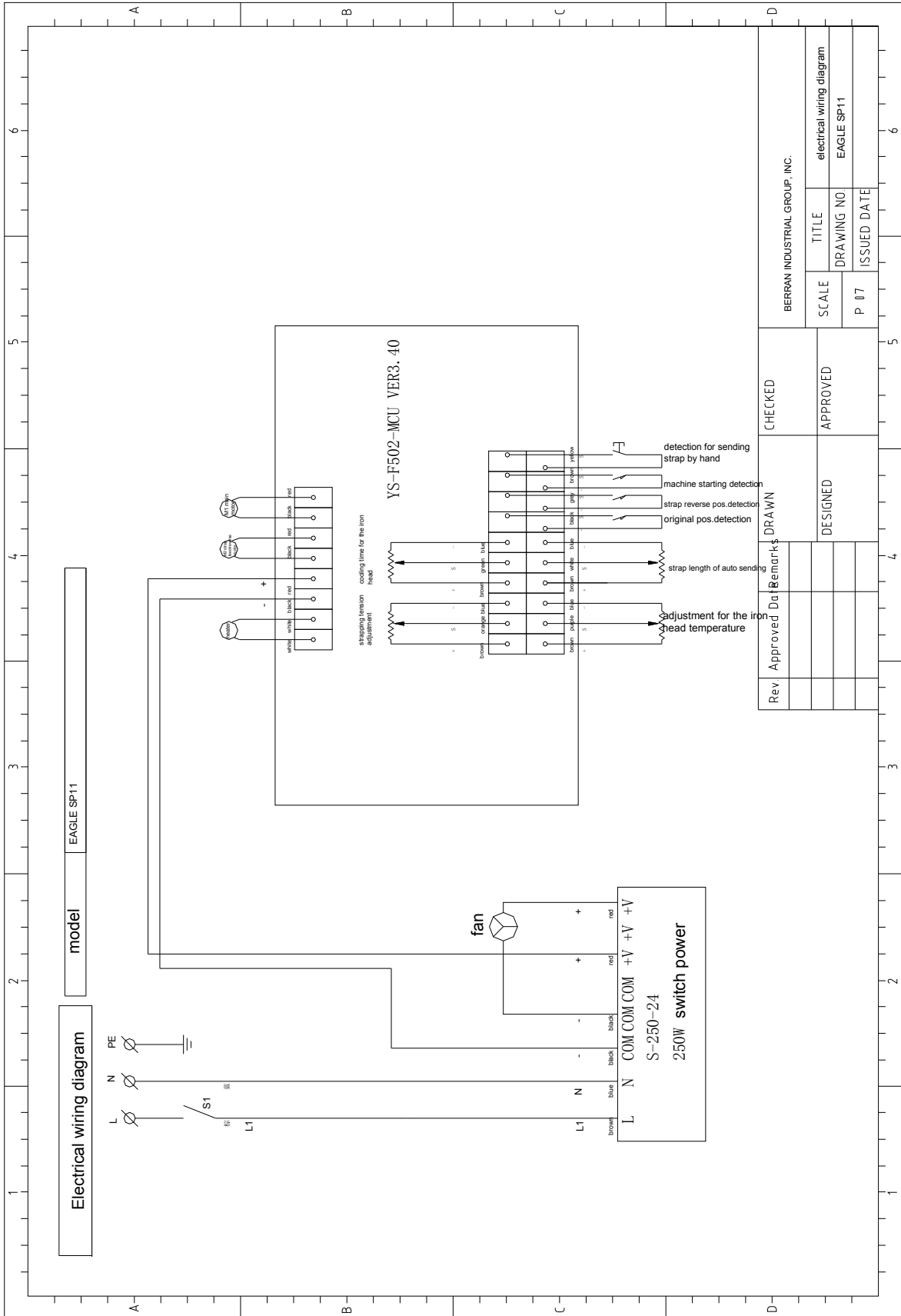

Rev	Approved Date	Remarks	DRAWN	CHECKED	BERRAN INDUSTRIAL GROUP, INC.	
				APPROVED	SCALE	TITLE
				DESIGNED	DRAWING NO	electrical wiring diagram
				P 07	ISSUED DATE	EAGLE SP11