

# Inline L-Clip

A FULLY-AUTOMATED CASE SEALER



The Inline L-Clip is available in three sizes to cover a wide range of box widths!



Pictured: Dual Head Top Inline L-Clip Machine

**The EdgeTec Inline L-Clip Taper is a fully automated case sealing machine for end-of-line use. It is capable of sealing up to 70 boxes a minute, dependent on box size.**

A uniquely versatile design, the Inline L-Clip can run one to five tape heads, mounted in practically any position. These tape heads allow users to apply any combination of leading and/or trailing L-Clips of tape and center seam tape.

The machine can seal both RSC-style boxes and non-RSC-style boxes. Such as: five-panel folders, full overlap, telescoping, tuck fold, roll end tuck, and custom boxes.

Accurate and secure tape application means no tape waste. Additionally, a bypass mode keeps production lines moving when certain tape heads are not needed.

## Common Inline L-Clip Taping Configurations



Top L-Clip



Bottom L-Clip



C-Clip  
(For boxes under 2')



Center Seam Top and Bottom



Leading and Trailing Top L-Clips

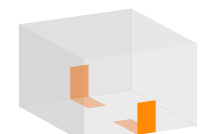

Leading and Trailing Bottom L-Clips



Leading Dual Head Top L-Clips



Leading Dual Head Bottom L-Clips



Leading and Trailing Dual Head Top L-Clips



Leading and Trailing Dual Head Bottom L-Clips



Bypass Mode

More Options Available!

## Inline L-Clip

**Adjustable Crank Arms**  
Quickly change between box sizes by adjusting width and height crank arms

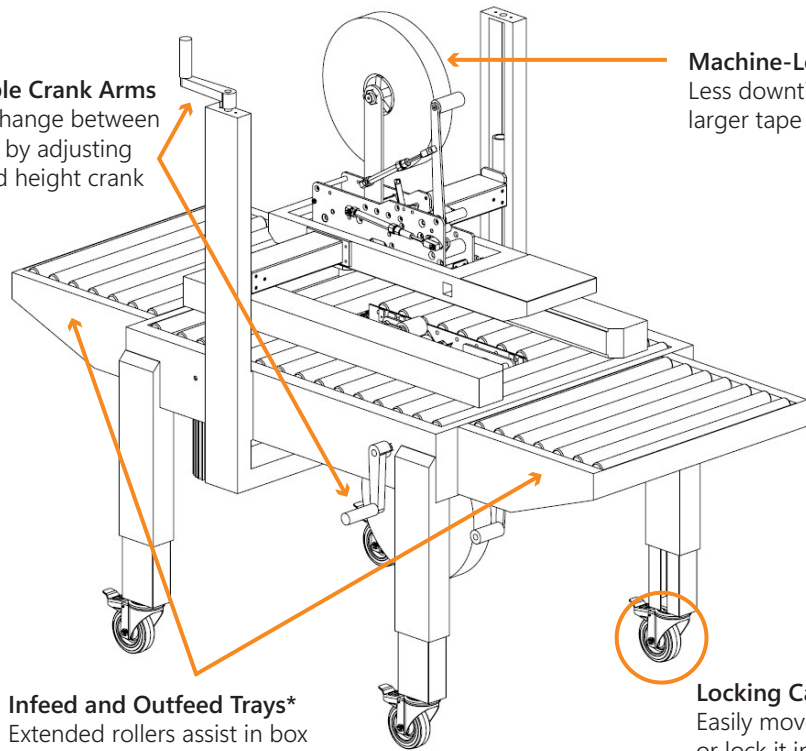

**Machine-Length Rolls**  
Less downtime with larger tape rolls.

**Infeed and Outfeed Trays\***  
Extended rollers assist in box loading and unloading.

**Locking Casters**  
Easily move the machine or lock it in place.

\*Optional Feature

## Three Machine Sizes

We have three machine sizes that can fit your widest and smallest boxes.

## Tape Widths

Whatever tape you are running, we have a head that can apply it! 1", 2", 3"? We've got you covered.

## Need something different?

We also sell tape head units that can mount to existing conveyors or have fully automated solutions for random boxes.

## Inline L-Clip Machine Specifications

<b>Machine Type</b>	Top or bottom case sealer, uniform side belt drive
<b>Machine Makeup</b>	Framework: Industrial strength 12-gauge steel, powder coated for durability, or stainless steel High-grade industrial components
<b>Working Speed</b>	66 ft/min belt speed (Speed can be changed based on customer needs.)
<b>Machine Dimensions (L x W x H)</b>	Small Box Machine: 36" x 32.25" x 42" Medium Box Machine: 50.5" x 53.5" x 50" Large Box Machine: 66" x 68" x 77"
<b>Machine Weight</b>	Small: 350 lbs    Medium: 400 lbs    Large: 450 lbs
<b>Tape Sizes</b>	Standard: 2" wide pressure sensitive tape, up to 15" diameter rolls Optional: 3" wide tape Optional: Custom tape widths between 1/2" to 2"
<b>Tape Heads</b>	2" Tape: 5.00 inches minimum distance between heads 3" Tape: 5.50 inches minimum distance between heads
<b>Tape Styles</b>	Filament, BOPP, Flat Back, PVC
<b>Electrical Requirements</b>	110 VAC, 50/60Hz, 1 Phase Power or 220VAC 50/60Hz, 1 Phase Power
<b>Tape Leg Length</b>	Standard machine applies up to 2.25" on the vertical box wall and a minimum of 2.5" on the horizontal box wall consistently.

## Optional Features

<b>Infeed/Outfeed Trays</b>	Rollers are extended to assist in the loading and unloading of the machine.
<b>All-Electric</b>	The same high-quality taping machine, no compressed air needed.
<b>Inline Air Filter</b>	For situations where clean compressed air is not always available.
<b>Low Tape Sensor</b>	A sensor monitors tape level and will warn with an indicator light and horn when it's time to change tape.
<b>Hand Crank Counter</b>	Numerical dials are added to the cranks to ensure exact positioning of crank adjustments.
<b>Custom Tape Width</b>	Machine adjusted to run a custom tape width.

## Box Specifications (LxWxH)

### Small Box Machine

**Minimum Box Size**  
4.5" x 4" x 0.875"

**Maximum Box Size**  
∞ x 19.7" x 19.7"

### Medium Box Machine

**Minimum Box Size**  
6" x 5.7" x 0.875"

**Maximum Box Size**  
∞ x 35.4" x 19.7"

### Large Box Machine

**Minimum Box Size**  
12" x 10" x 1"

**Maximum Box Size**  
∞ x 54" x 10"